



LOW-PROFILE COMMERCIAL LH2000i Heat Recovery Ventilator

PRODUCT
SPECIFICATIONS
& TECHNICAL
DATA

Standard Features



NOMINAL CAPACITY

1000-2500 CFM

CASING

Double-wall cabinet
22-gauge galvanized steel interior and exterior
Access doors with quarter-turn handles
18-gauge galvanized steel drain pan
Drain Connections: 1" NPT
Insulation: 1" (25 mm)

MOUNTING

On platform or suspended by chains

PLATE EXCHANGER

Standard: Polypropylene
Quantity: 3
Pitch: 0.12" (3 mm)
Dimensions: 16.03" x 16.03" x 15.67"
(407 mm x 407 mm x 398 mm)



Optional: Aluminum

Quantity: 3
Pitch: 0.13" (3.3 mm)
Dimensions: 16.34" x 16.34" x 15.67"
(415 mm x 415 mm x 398 mm)



BLOWERS

Quantity: 2

- Forward-curved
- Permanently sealed and lubricated ball bearings
- Power transmission by adjustable pulleys and belts

MOTORS

Quantity: 2

- Type: Inverter duty 10:1, ODP or TEFC, EAct or Premium
- Maximum Power: 3 hp
- Drive Assembly/Blower: On vibration-isolating rubber

FILTERS

Quantity: 2 per circuit

- Type: MERV 8
- Dimensions: 12" x 24" x 4" (305 mm x 610 mm x 102 mm)

ELECTRICAL & CONTROLS

- Start/stop dry contact and general alarm dry contact
- Occupancy control dry contact
- Fan interlock dry contact
- 24VAC, 20VA power available for accessories
- Access panel to control panel with non-fused disconnect (NEMA 4)
- Single-point power connection
- 120, 208, 230 V / 1ph / 60Hz
- 208, 230, 460, 575 V / 3ph / 60Hz

WARRANTY

- Core: Limited 10-year warranty
- All Other Covered Components: Limited 2-year warranty

LISTED BY



Optional Features

CABINET

- Painted white baked enamel outside finish
- Pool Construction: TEFC motors, stainless steel interior, and epoxy-coated fans
- Vibration-isolating springs under blowers
- Motorized and insulated damper for exhaust port (EA)
- Non-insulated backdraft damper for exhaust port (EA)
- Motorized and insulated damper for fresh air intake (OA) (standard with exhaust defrost and recirculation)
- 18-gauge stainless steel drain pan
- MERV 13 filters (for supply air circuit only)

MOTORS & BLOWERS

- TEFC motors (premium available with ≥ 1.5 hp/3ph)
- 2-speed motors (only available with ODP, EPAct motors)
- Programmable 2-Speed (VFD)
- Variable Frequency Drive (VFD): 0-10VDC external signal

FROST CONTROL

Frost control activated by a temperature reference: 23°F (-5°C)

- Internal Pre-Heat by Electric Coil: Powered by unit, factory calibrated, SCR control (unavailable with 120 V)
- Internal Pre-Heat by Hot Water Coil: 0-10 V signal on the control panel
- Exhaust Defrost Cycles: Supply air blower shuts down and outside air damper (included) closes. Warm exhaust air defrosts the core for a predetermined amount of time.
- Recirculation Defrost Cycles: Exhaust air blower shuts down, outside air damper (included) closes, exhaust air damper (optional) closes, and recirculation damper (included) opens. Exhaust air warms up the core for a predetermined amount of time.

POST-HEAT COILS

- Post-Heat by Electric Coil: Powered by unit, SCR Control, external 0-10VDC control signal
- Post-Heat by Water Coil: External 0-10VDC control signal
- Contact Aldes for Coil Sizing

CONTROLS

- Low Temperature Limit: Unit will stop if fresh air supply is under set point (adjustable)
- Dirty Filters Contact: Will close a dry contact when dirty filters are detected
- Low Airflow Switch: Will open a dry contact when no airflow is detected on supply blower
- Phase Loss Detection: Unit will stop when a phase loss occurs, automatic restart (3-phase power only)
- Damper End Switch: Unit start up conditional to dampers opening
- Recirculation Dry Contact: For unoccupied mode, must select recirculation defrost option
- Programmable Timer
- BacNet Compatible Controller
 - Available Upgrades:
 - » IP Communication Network Module
 - » MS/TP Communication Network Module
 - » Remote Keypad
 - » Remote Keypad with Touchscreen

MAXIMUM kW PER ELECTRIC COIL	
120V/1ph/60Hz	--
208V/1ph/60Hz	37 kW
230V/1ph/60Hz	43 kW
208V/3ph/60Hz	54 kW
230V/3ph/60Hz	54 kW
460V/3ph/60Hz	54 kW
575V/3ph/60Hz	54 kW

MAXIMUM MBH PER HOT WATER COIL: 98 MBH

Dimensions

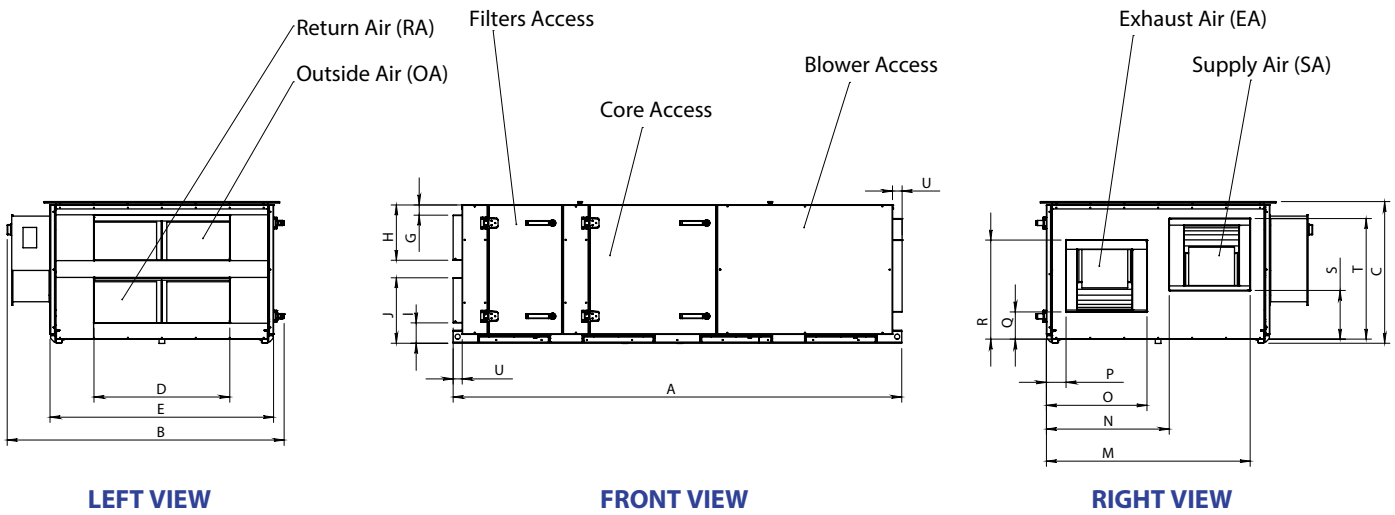
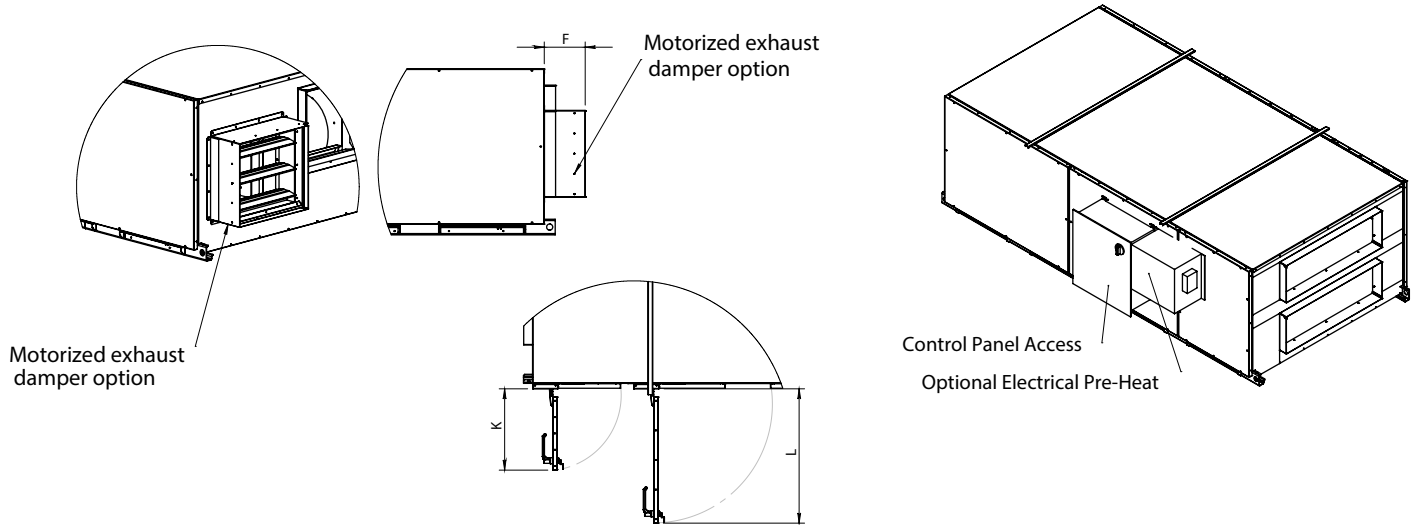

DIMENSIONS*																					
Unit	Overall			Openings																Doors	
	A	B	C	D	E	F	G	H	I	J	M	N	O	P	Q	R	S	T	U	K	L
Standard	99.13 (2518)	63 (1600)	31.63 (803)	30 (762)	49.38 (1254)	7.5 (191)	2.25 (57)	12.25 (311)	4.5 (114)	14.5 (368)	45 (1143)	27.13 (689)	22.25 (565)	4.38 (111)	6.03 (153)	21.9 (556)	10.75 (273)	26.63 (676)	2 (51)	18 (457)	29.75 (756)
Post-Heat Option	119.13 (3026)	63 (1600)	36.63 (930)	30 (762)	49.38 (1254)	7.5 (191)	2.25 (57)	12.25 (311)	4.5 (114)	14.5 (368)	45 (1143)	27.13 (689)	22.25 (565)	4.38 (111)	6.03 (153)	21.9 (556)	10.75 (273)	26.63 (676)	2 (51)	18 (457)	29.75 (756)

*All dimensions in inches (mm)

Configurations & Weights

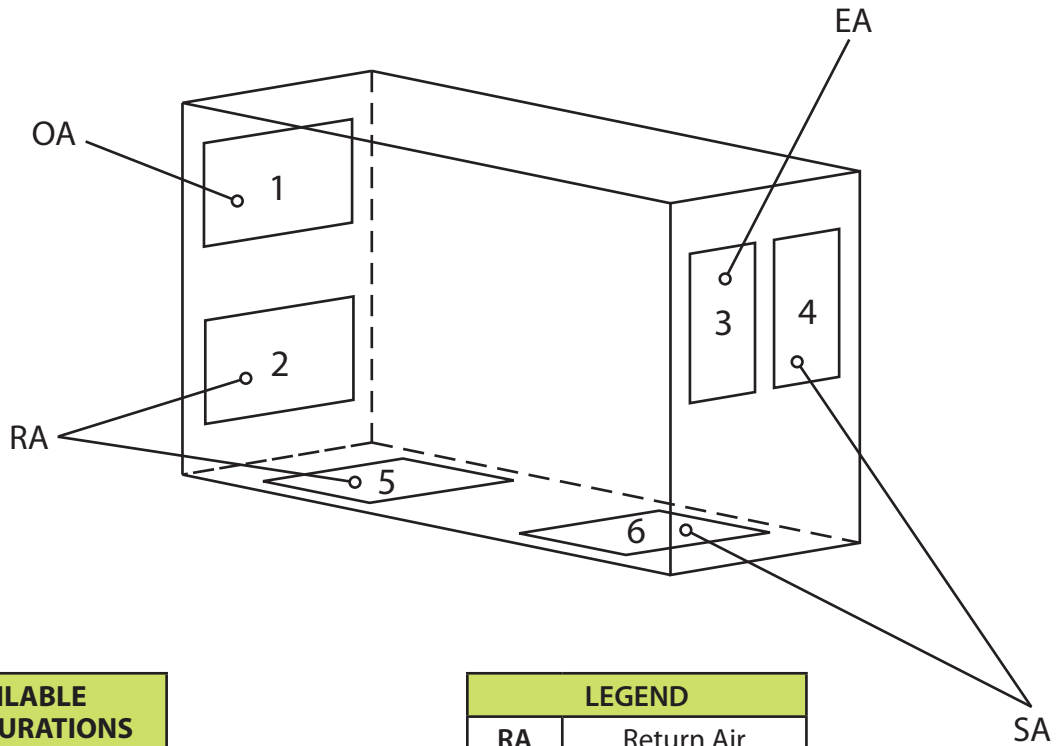

AVAILABLE CONFIGURATIONS
1-2-3-4
1-2-3-6
1-3-4-5
1-3-5-6

LEGEND	
RA	Return Air
SA	Supply Air
OA	Outside Air
EA	Exhaust Air

Mirror Image Cabinet Also Available

WEIGHT - LH2000i †		
Weight	Core	
	Polypropylene	Aluminum
Unit Weight (Minimum)	978 lb (444 kg)	1020 lb (463 kg)
Unit Weight (Maximum)	1311 lb (595 kg)	1353 lb (614 kg)
Shipping Weight (Minimum)	1063 lb (482 kg)	1105 lb (501 kg)
Shipping Weight (Maximum)	1396 lb (633 kg)	1438 lb (652 kg)

† Actual weight may vary by ±10%.

Polypropylene Core Performance

AHRI STANDARD CONDITIONS	CONDITIONS	
Outside Air Temperature	Winter	Summer
Dry Bulb	35°F (1.7°C)	95°F (35°C)
Wet Bulb	33°F (0.6°C)	78°F (25.6°C)
Return Air Temperature	Winter	Summer
Dry Bulb	70°F (21.1°C)	75°F (23.9°C)
Wet Bulb	58°F (14.4°C)	63°F (17.2°C)

Note: Efficiencies are based on AHRI standard winter conditions.

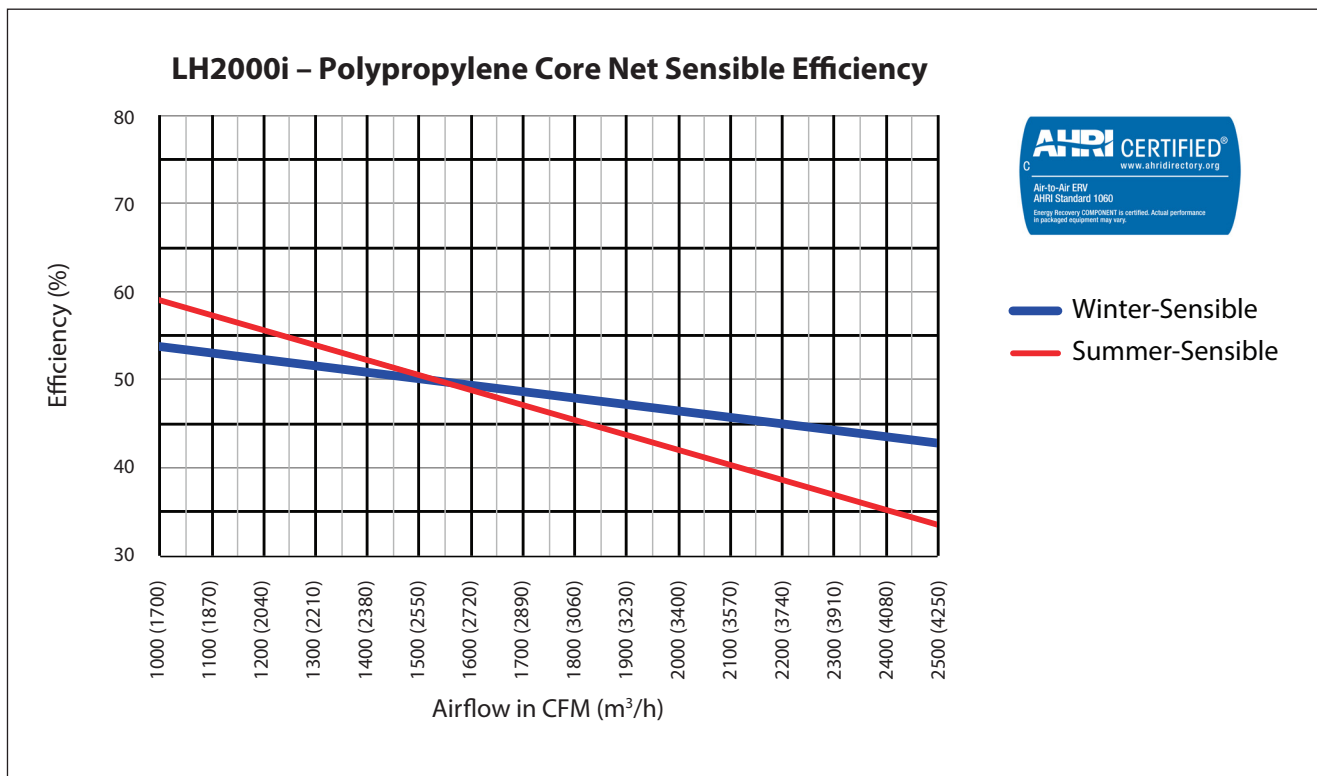

Aluminum Core Performance

AHRI STANDARD CONDITIONS	CONDITIONS	
Outside Air Temperature	Winter	Summer
Dry Bulb	35°F (1.7°C)	95°F (35°C)
Wet Bulb	33°F (0.6°C)	78°F (25.6°C)
Return Air Temperature	Winter	Summer
Dry Bulb	70°F (21.1°C)	75°F (23.9°C)
Wet Bulb	58°F (14.4°C)	63°F (17.2°C)

Note: Efficiencies are based on AHRI standard winter conditions.

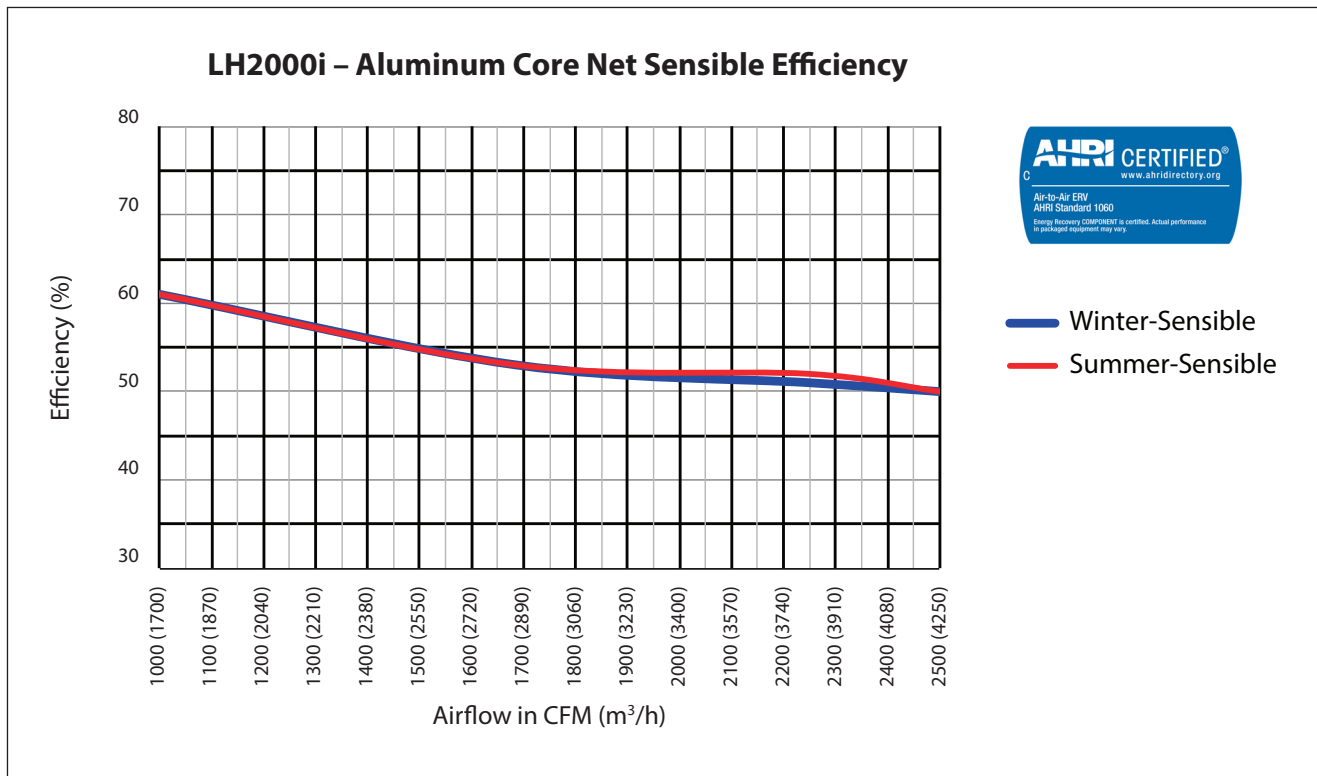

Motor Selection – Polypropylene Core

SUPPLY																				
MOTOR	AIRFLOW	EXTERNAL STATIC PRESSURE (inH ₂ O) - SUPPLY																		MOTOR
		0.25 (60 Pa)			0.50 (125 Pa)			0.75 (185 Pa)			1.00 (250 Pa)			1.25 (310 Pa)			1.50 (375 Pa)			
		CFM (m ³ /h)	RPM	BHP	HP	RPM	BHP	HP	RPM	BHP	HP	RPM	BHP	HP	RPM	BHP	HP	RPM	BHP	
3/4 hp	1000 (1700)	818	0.22	0.27	932	0.29	0.35	1032	0.36	0.43	1121	0.43	0.52	1201	0.51	0.61	1272	0.58	0.70	3/4 hp
	1100 (1870)	842	0.26	0.31	953	0.33	0.40	1051	0.41	0.49	1139	0.48	0.58	1220	0.57	0.68	1292	0.64	0.77	1 hp
	1200 (2040)	865	0.31	0.37	972	0.38	0.46	1069	0.46	0.55	1157	0.54	0.65	1238	0.63	0.76	1311	0.71	0.86	1 hp
	1300 (2210)	888	0.35	0.42	992	0.43	0.52	1086	0.52	0.62	1174	0.60	0.72	1255	0.70	0.84	1329	0.78	0.94	1 hp
	1400 (2380)	910	0.41	0.49	1011	0.49	0.59	1103	0.58	0.69	1191	0.66	0.80	1271	0.77	0.92	1346	0.86	1.03	1.5 hp
	1500 (2550)	932	0.46	0.55	1029	0.55	0.66	1120	0.64	0.77	1206	0.73	0.88	1287	0.84	1.01	1361	0.94	1.13	1.5 hp
	1600 (2720)	953	0.52	0.63	1048	0.61	0.74	1136	0.71	0.85	1221	0.81	0.97	1301	0.92	1.10	1376	1.02	1.22	1.5 hp
1 hp	1700 (2890)	973	0.59	0.70	1065	0.68	0.82	1152	0.78	0.94	1236	0.88	1.06	1315	1.00	1.20	1389	1.10	1.33	1.5 hp
	1800 (3060)	993	0.65	0.79	1082	0.75	0.90	1167	0.86	1.03	1249	0.96	1.15	1327	1.08	1.30	1401	1.19	1.43	2 hp
	1900 (3230)	1013	0.73	0.87	1099	0.83	1.00	1182	0.94	1.13	1262	1.05	1.26	1339	1.17	1.40	1412	1.29	1.54	2 hp
1.5 hp	2000 (3400)	1032	0.80	0.96	1115	0.91	1.09	1196	1.02	1.23	1275	1.13	1.36	1350	1.26	1.52	1422	1.38	1.66	2 hp
	2100 (3570)	1050	0.88	1.06	1131	1.00	1.20	1209	1.11	1.33	1286	1.23	1.47	1360	1.36	1.63	1430	1.48	1.78	2 hp
	2200 (3740)	1068	0.97	1.16	1147	1.09	1.30	1223	1.20	1.45	1297	1.32	1.59	1369	1.46	1.75	1438	1.58	1.90	2 hp
	2300 (3910)	1085	1.06	1.27	1162	1.18	1.42	1235	1.30	1.56	1307	1.42	1.71	1377	1.56	1.87	1444	1.69	2.03	3 hp
	2400 (4080)	1101	1.15	1.38	1176	1.28	1.53	1247	1.40	1.68	1317	1.53	1.84	1385	1.67	2.00	1449	1.80	2.16	3 hp
2500 (4250)	1117	1.25	1.50	1190	1.38	1.66	1259	1.51	1.81	1326	1.64	1.97	1391	1.78	2.13	1453	1.91	2.29	3 hp	

EXHAUST																				
MOTOR	AIRFLOW	EXTERNAL STATIC PRESSURE (inH ₂ O) - EXHAUST																		MOTOR
		0.25 (60 Pa)			0.50 (125 Pa)			0.75 (185 Pa)			1.00 (250 Pa)			1.25 (310 Pa)			1.50 (375 Pa)			
		CFM (m ³ /h)	RPM	BHP	HP	RPM	BHP	HP	RPM	BHP	HP	RPM	BHP	HP	RPM	BHP	HP	RPM	BHP	
3/4 hp	1000 (1700)	732	0.18	0.22	858	0.25	0.30	967	0.32	0.39	1065	0.39	0.47	1150	0.46	0.55	1227	0.53	0.64	3/4 hp
	1100 (1870)	747	0.21	0.25	868	0.28	0.34	976	0.36	0.43	1072	0.43	0.51	1158	0.50	0.60	1236	0.58	0.70	3/4 hp
	1200 (2040)	762	0.24	0.29	880	0.31	0.38	985	0.39	0.47	1080	0.47	0.56	1167	0.55	0.66	1246	0.63	0.76	1 hp
	1300 (2210)	778	0.28	0.33	892	0.35	0.42	995	0.44	0.52	1089	0.51	0.62	1176	0.60	0.72	1256	0.69	0.83	1 hp
	1400 (2380)	795	0.32	0.38	906	0.40	0.47	1006	0.49	0.58	1098	0.56	0.68	1185	0.65	0.79	1266	0.75	0.90	1 hp
	1500 (2550)	813	0.36	0.44	920	0.45	0.53	1018	0.54	0.65	1108	0.62	0.74	1195	0.72	0.86	1276	0.82	0.98	1.5 hp
	1600 (2720)	832	0.42	0.50	935	0.50	0.60	1031	0.60	0.72	1119	0.68	0.82	1205	0.78	0.94	1286	0.89	1.07	1.5 hp
	1700 (2890)	851	0.47	0.57	951	0.56	0.67	1044	0.66	0.79	1131	0.75	0.90	1216	0.86	1.03	1296	0.97	1.16	1.5 hp
	1800 (3060)	871	0.53	0.64	967	0.63	0.75	1058	0.73	0.88	1143	0.82	0.99	1227	0.93	1.12	1307	1.05	1.26	1.5 hp
1 hp	1900 (3230)	892	0.60	0.72	985	0.70	0.84	1074	0.80	0.97	1157	0.90	1.08	1239	1.02	1.22	1317	1.14	1.36	2 hp
	2000 (3400)	913	0.67	0.81	1004	0.77	0.93	1090	0.88	1.06	1171	0.99	1.18	1251	1.10	1.33	1328	1.23	1.47	2 hp
	2100 (3570)	935	0.75	0.90	1023	0.86	1.03	1107	0.97	1.16	1185	1.07	1.29	1264	1.20	1.44	1339	1.32	1.59	2 hp
1.5 hp	2200 (3740)	959	0.83	1.00	1044	0.94	1.13	1124	1.06	1.27	1201	1.17	1.40	1277	1.30	1.56	1350	1.42	1.71	2 hp
	2300 (3910)	982	0.92	1.10	1065	1.04	1.24	1143	1.15	1.38	1217	1.27	1.52	1291	1.40	1.68	1361	1.53	1.84	3 hp
	2400 (4080)	1007	1.01	1.21	1087	1.13	1.36	1162	1.25	1.50	1234	1.38	1.65	1305	1.51	1.82	1372	1.64	1.97	3 hp
2500 (4250)	1032	1.11	1.33	1110	1.24	1.49	1183	1.36	1.63	1252	1.49	1.79	1319	1.64	1.95	1384	1.76	2.11	3 hp	

NOTES:

hp = bhp x 1.2

See page 8 for Additional Pressure Drop (APD) with MERV 13 Filters

Contact Aldes for Additional Pressure Drop (APD) with Hot Water or Electric Coils

Motor Selection – Aluminum Core

SUPPLY/EXHAUST																				
MOTOR	AIRFLOW	EXTERNAL STATIC PRESSURE (inH ₂ O) - SUPPLY/EXHAUST																		MOTOR
		0.25 (60 Pa)			0.50 (125 Pa)			0.75 (185 Pa)			1.00 (250 Pa)			1.25 (310 Pa)			1.50 (375 Pa)			
		CFM (m ³ /h)	RPM	BHP	HP	RPM	BHP	HP	RPM	BHP	HP	RPM	BHP	HP	RPM	BHP	HP	RPM	BHP	
3/4 hp	1000 (1700)	806	0.22	0.27	922	0.28	0.34	1024	0.35	0.42	1114	0.43	0.52	1195	0.51	0.61	1268	0.58	0.70	3/4 hp
	1100 (1870)	817	0.25	0.30	930	0.31	0.38	1031	0.39	0.47	1121	0.47	0.57	1203	0.55	0.66	1277	0.63	0.76	1 hp
	1200 (2040)	828	0.28	0.34	938	0.35	0.42	1038	0.43	0.52	1127	0.52	0.62	1210	0.60	0.71	1286	0.69	0.82	
	1300 (2210)	839	0.32	0.38	947	0.39	0.47	1045	0.48	0.57	1134	0.56	0.68	1218	0.65	0.78	1294	0.74	0.89	
	1400 (2380)	851	0.36	0.43	956	0.43	0.52	1053	0.53	0.63	1142	0.61	0.74	1225	0.70	0.85	1303	0.81	0.97	1.5 hp
	1500 (2550)	864	0.40	0.48	967	0.48	0.58	1061	0.58	0.70	1149	0.67	0.81	1233	0.77	0.92	1311	0.87	1.05	
	1600 (2720)	877	0.45	0.54	977	0.54	0.64	1070	0.64	0.76	1157	0.73	0.88	1241	0.83	1.00	1319	0.94	1.13	
	1700 (2890)	891	0.51	0.61	989	0.59	0.71	1080	0.70	0.84	1166	0.80	0.96	1248	0.90	1.08	1326	1.01	1.22	
	1800 (3060)	905	0.57	0.68	1001	0.66	0.79	1090	0.77	0.92	1174	0.87	1.04	1256	0.97	1.17	1333	1.09	1.31	
1900 (3230)	921	0.63	0.75	1013	0.73	0.87	1101	0.84	1.00	1183	0.94	1.13	1264	1.05	1.26	1340	1.17	1.41		
1 hp	2000 (3400)	936	0.70	0.84	1026	0.80	0.96	1112	0.91	1.09	1193	1.02	1.22	1272	1.14	1.36	1347	1.26	1.51	2 hp
	2100 (3570)	952	0.77	0.92	1040	0.87	1.05	1123	0.99	1.19	1202	1.10	1.32	1280	1.22	1.47	1354	1.35	1.62	
1.5 hp	2200 (3740)	969	0.84	1.01	1055	0.96	1.15	1135	1.07	1.29	1213	1.19	1.43	1288	1.31	1.58	1360	1.44	1.73	
	2300 (3910)	987	0.92	1.11	1070	1.04	1.25	1148	1.16	1.39	1223	1.28	1.54	1296	1.41	1.69	1366	1.54	1.85	
	2400 (4080)	1005	1.01	1.21	1086	1.13	1.36	1161	1.25	1.50	1234	1.38	1.65	1304	1.51	1.81	1372	1.64	1.97	
	2500 (4250)	1024	1.10	1.32	1102	1.23	1.47	1175	1.35	1.62	1245	1.48	1.77	1312	1.62	1.94	1377	1.75	2.10	3 hp

NOTES:

hp = bhp x 1.2

Contact Aldes for Additional Pressure Drop (APD) with Hot Water or Electric Coils

Additional Air Pressure Drop with MERV 13 Filters

Airflow CFM (m ³ /h)	APD inH ₂ O (Pa)
1000 (1700)	0.02 (4)
1100 (1870)	0.02 (4)
1200 (2040)	0.02 (4)
1300 (2210)	0.03 (6)
1400 (2380)	0.03 (6)
1500 (2550)	0.03 (6)
1600 (2720)	0.03 (6)
1700 (2890)	0.04 (7)

Airflow CFM (m ³ /h)	APD inH ₂ O (Pa)
1800 (3060)	0.04 (7)
1900 (3230)	0.04 (7)
2000 (3400)	0.05 (11)
2100 (3570)	0.05 (11)
2200 (3740)	0.05 (11)
2300 (3910)	0.06 (12)
2400 (4080)	0.06 (12)
2500 (4250)	0.06 (12)

Selection Information

▲ = Standard Feature

☐ = Optional Feature (check the box to select this option)

Send your completed selection to your American ALDES Representative.

MODEL

Series: Low-Profile Commercial (LH)

Nominal Capacity: 1000-2500 CFM

Application: Interior (i)

CASING

Cabinet Finish

- Galvanized
- Painted
- Pool Construction

Duct Configuration (see pg. 4)

- 1-2-3-4
- 1-2-3-6
- 1-3-4-5
- 1-3-5-6

Mirror Image Cabinet

- Optional

Drain Pan

- Galvanized
- Stainless Steel

Plate Exchanger

- Polypropylene
- Aluminum

FROST CONTROL

- None
- Exhaust Defrost ¹
- Recirculation ¹
- Pre-Heat (Electric Coil)
- Pre-Heat (Hot Water Coil)

FILTERS (SUPPLY)

- MERV 8
- MERV 13

BLOWERS & MOTORS

Supply Blower

- 3/4 hp
- 1 hp
- 1.5 hp
- 2 hp
- 3 hp

Exhaust Blower

- 3/4 hp
- 1 hp
- 1.5 hp
- 2 hp
- 3 hp

Motor Type

- ODP, EPAAct ²
- ODP, Premium ³
- TEFC, EPAAct ²
- TEFC, Premium ⁴

Blower Control

- Single Speed
- 2-Speed ⁵
- Programmable 2-Speed (VFD)
- VFD

Drive Assembly/Blower

- On vibration-isolating rubber
- On vibration-isolating springs

POST-HEAT COILS

- Electric Coil
- Hot Water Coil

ELECTRICAL REQUIREMENTS

- 120V/1ph/60Hz
- 208V/1ph/60Hz
- 230V/1ph/60Hz
- 208V/3ph/60Hz
- 230V/3ph/60Hz
- 460V/3ph/60Hz
- 575V/3ph/60Hz

ADD-ONS

- Motorized & Insulated Damper for EA
- Non-Insulated Backdraft Damper for EA
- Motorized & Insulated Damper for OA ¹
- Low Temperature Limit
- Dirty Filters Contact
- Low Airflow Switch
- Phase Loss Detection
- Damper End Switch
- Recirculation Dry Contact ⁶
- Programmable Timer
- BacNet Compatible Controller
 - With IP Module
 - With MS/TP Module
 - With Remote Keypad
 - With Remote Keypad (Touchscreen)
- Spare MERV 8 Filters QTY: _____
- Spare Belts QTY: _____

¹ OA Motorized & Insulated Damper included with exhaust defrost and recirculation; recirculation damper included with recirculation defrost

² EPAAct efficiency only available when Premium efficiency is not available (e.g., with single-phase motors)

³ ODP, Premium only available with ≥3 hp/ 3ph motors

⁴ TEFC, Premium only available with ≥ 1.5 hp/ 3ph motors

⁵ 2-Speed only available with ODP, EPAAct motors

⁶ Recirculation Dry Contact requires selection of recirculation defrost

Project:		Architect:	
Location:		Engineer:	
Model #:		Contractor:	
Quantity:		Comments:	
Submitted By:			
Date:			